

ACDEU

Priming Assisted Centrifugal Pump



Diesel Engine Driven Model PA4A60-4045D Size 4" x 4"



Total Head		Capacity of Pump in U.S. Gallons per Minute (GPM) at Continuous Performance			
P.S.I.	Feet				
58.1	134	220	220	220	220
52.0	120	370	420	420	420
43.4	100	392	545	670	730
34.7	80	405	555	682	810
26.0	60	415	565	694	830
17.3	40	425	575	708	860
Suction Lift		25'	20'	15'	10'

PUMP SPECIFICATIONS

Size: 4" x 4" (102 mm x 102 mm) Flanged.

Casing: Gray Iron No. 30. Maximum Operating Pressure 99 psi (683 kPa).*

Open Type, Two Vane Impeller: Ductile Iron No. 65-45-12. Handles 3" (76 mm) Diameter Spherical Solids.

Impeller Shaft: Alloy Steel No. 4140.

Replaceable Wear Plate: Steel No. 1018.

Intermediate Bracket: Gray Iron No. 30.

Seal Plate: Gray Iron No. 30.

Seal: Mechanical, Oil-Lubricated, Double Floating, Self-Aligning. Silicon Carbide Rotating and Stationary Faces. Stainless Steel No. 316 Stationary Seat. Fluorocarbon Elastomers (DuPont Viton® or Equivalent). Stainless Steel No. 18-8 Cage and Spring. Maximum Temperature of Liquid Pumped 160°F (71°C).*

Shaft Sleeve: Stainless Steel No. 17-4 PH.

Priming Chamber: Gray Iron No. 30.

Discharge Check Valve: Gray Iron No. 30 Housing w/Buna-N Flapper.

Radial Bearing: Open Single Ball.

Thrust Bearing: Open Double Ball.

Bearing and Seal Cavity Lubrication: SAE No. 30 Non-Detergent Oil.

Flanges: Gray Iron No. 30.

Gaskets: Resistant Synthetic Rubber, Cork, PTFE, Vegetable Fiber and Compressed Synthetic Fibers.

O-Rings: Buna-N.

Hardware: Standard Plated Steel.

Bearing and Seal Cavity Oil Level Sight Gauges.

**Consult Factory for Applications Exceeding Maximum Pressure and/or Temperature Indicated.*

Standard Equipment: Gear-Driven Air Compressor. Hoisting Bail. Combination Skid Base w/Fuel Tank. Strainer. Single Ball Type Float Switch.**

***50 Ft. (15 m) Standard Length; Dual Switches and Alternate Cable Lengths Available From the Factory.*

Optional Equipment: Battery. High Speed (55 MPH/89 KM/H) Wheel Kit with ST205/75R14 Pneumatic Tires. Over-the-Road Trailer (Meets D.O.T. and Transport Canada Requirements) Available w/ Either Electric or Hydraulic Surge Brakes, Running Lights, Two Trailer Jack Stands and Safety Chains. EPS w/Submersible Transducer Liquid Level Sensor (50 Ft. [15 M] Cable Standard, Alternate Lengths Available).



ENGINE SPECIFICATIONS

Model: John Deere 4045D "Power Tech".

Type: Four Cylinder, Four Cycle, Liquid Cooled Diesel Engine.

Displacement: 276 Cu. In. (4,5 Liters).

Governor: Mechanical.

Lubrication: Forced Circulation.

Air Cleaner: Dry Type.

Oil Reservoir: 9 U.S. Qts. (8,5 Liters) Dry; 8 U.S. Qts. (7,6 Liters) Refill.

Fuel Tank: 61 U.S. Gals. (231 Liters).

Full Load Operating Time: 29 Hrs.

Starter: 12V Electric.

Standard Features: Low Oil Pressure and High Coolant Temperature Safety Shut Down Switches. Autostart Instrument Panel Includes: Tachometer, Voltmeter, Hourmeter, Coolant Temperature Gauge, Oil Pressure Gauge, Manual/Stop/Auto Key Switch, 10 Amp Push-button Circuit Breaker, Startup Warning Delay, Muffler w/Guard and Weather Cap. Throttle Control.

JOHN DEERE PUBLISHED PERFORMANCE:

Maximum Dynamic BHP 80 (60 kW) @ 2500 RPM
Maximum Continuous BHP 72 (54 kW) @ 2500 RPM



THE GORMAN-RUPP COMPANY • MANSFIELD, OHIO

GORMAN-RUPP OF CANADA LIMITED • ST. THOMAS, ONTARIO, CANADA

www.gormanrupp.com

Specifications Subject to Change Without Notice

Printed in U.S.A.

Specification Data

APPROXIMATE
DIMENSIONS and WEIGHTS

SKID BASE

2-WHEEL

NET WEIGHT:

2860 LBS. (1297 KG.)

3355 LBS. (1521 K.G.)

SHIPPING WEIGHT:

3105 LBS. (1408 KG.)

3355 LBS. (1521 K.G.)

EXPORT CRATE SIZE: 225 CU. FT. (6,4 CU. M.)

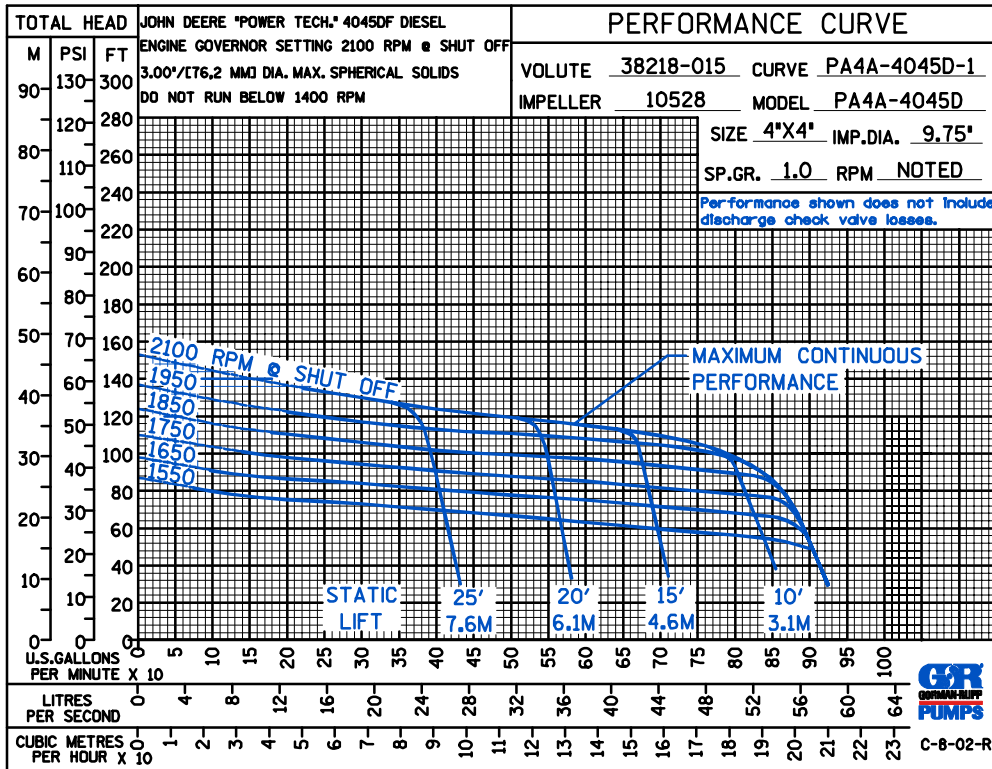
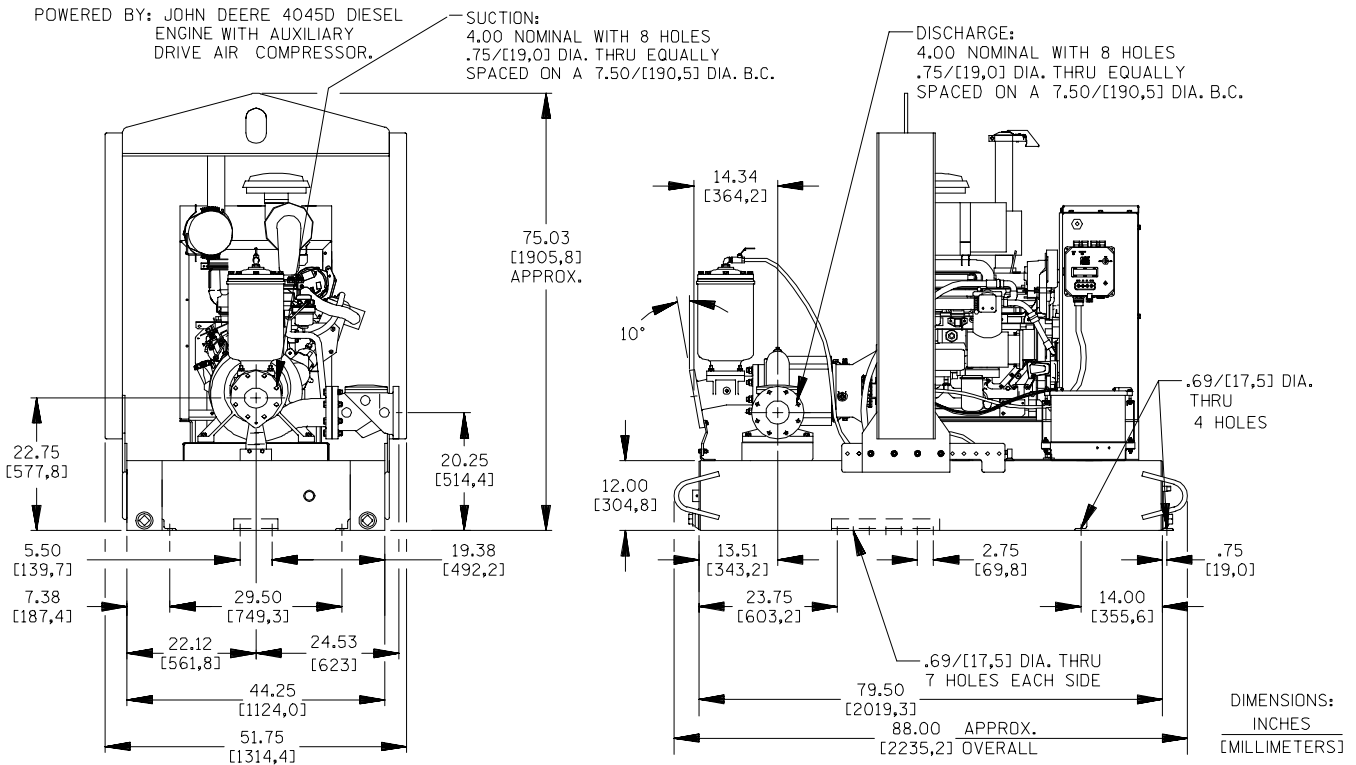

THE GORMAN-RUPP COMPANY • MANSFIELD, OHIO

GORMAN-RUPP OF CANADA LIMITED • ST. THOMAS, ONTARIO, CANADA

Specifications Subject to Change Without Notice

Printed in U.S.A.